

# Special 301, 302, 303, 304, 305, 306, 311



Notentriegelung

**Bei der Montage ist die Anleitung des Antriebs unbedingt zu berücksichtigen. Besonders die Sicherheitshinweise sind zu beachten!**

D



Emergency unlocking device

**When mounting please observe by all means the installation instructions of the operator. Pay special attention to the safety advice!**

GB



Déclenchement d'urgence

**Lors du montage, il faut absolument tenir compte des instructions concernant l'opérateur. Il est particulièrement important de respecter les consignes de sécurité!**

F



Noodontkoppeling

**Bij de montage moet de montage- bedieningshandleiding van de aandrijving in acht worden genomen. In het bijzonder dienen de veiligheidsinstructies te worden opgevolgd!**

NL



Sblocco di emergenza

**Per i lavori di montaggio osservare sempre le istruzioni di montaggio fornite in dotazione con la motorizzazione. Osservare in particolare gli avvisi di sicurezza!**

I



Desbloqueo de emergencia

**Al realizar el montaje es estrictamente necesario tener en cuenta las instrucciones del operador. ¡Hay que observar especialmente las indicaciones de seguridad!**

E



Destravamento de emergência

**Na montagem é indispensável considerar o manual do accionamento. Especialmente as indicações de segurança devem ser observadas!**

P



Nöduzlösning

**Vid monteringen skall anvisning för drivningen ovillkorligen beaktas. Speciellt säkerhetsanvisningarna skall beaktas!**

S



Nødåpning

**Det er tvingende nødvendig å følge bruksanvisningen for drivenheten under monteringen. Særlig sikkerhetsinstruksene må følges!**

N



Vészhelyzeti kireteszelés

**A szereléskor feltétlenül tekintetbe kell venni a kapuműködtető útmutatóját. Különösen a biztonságtechnikai útmutatásokat kell követni!**

H



Zasilno odpahovanje

**Pri montaži je potrebno brezpogojno upoštevati navodila pogona. Posebej se morajo upoštevati varnostna navodila!**

SLO



Nouzové odblokování

**Při montáži bezpodmínečně dodržujte montážní návod pro pohon. Zvláště pak dodržujte bezpečnostní pokyny!**

CZ



Ryglowanie awaryjne

**Podczas montażu należy koniecznie przestrzegać instrukcji napędu, a w szczególności wskazówek bezpieczeństwa!**

PL



Avarinis atsklendimas

**Montuodami būtina laikytis pavaros naudojimo vadovo. Ypatingai atkreipti dėmesį į saugos nuorodas!**

LT



Аварийная разблокировка

**Во время проведения монтажа необходимо принимать во внимание положения руководства по работе привода. В особенности следует учитывать указания по технике безопасности!**

RUS



Nødopløsning

**Ved montagen skal man ubetinget være opmærksom på vejledningen til drevet. Bemærk i særdeleshed sikkerhedshenvisninger!**

DK

# 1. Special 301, 302, 303, 304, 305, 311

1 / 1

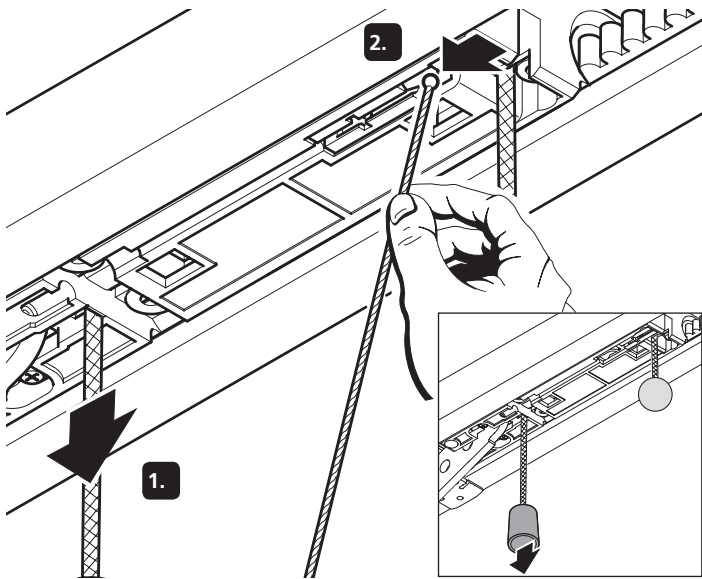

1 / 2

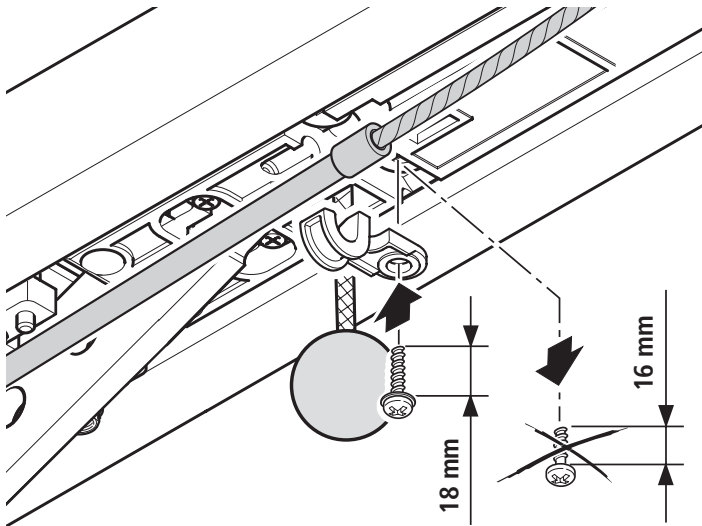

1 / 3

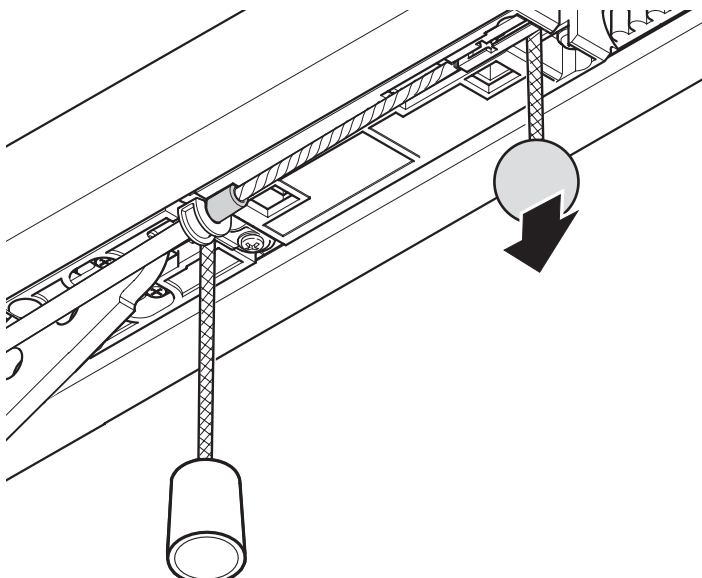

1 / 4

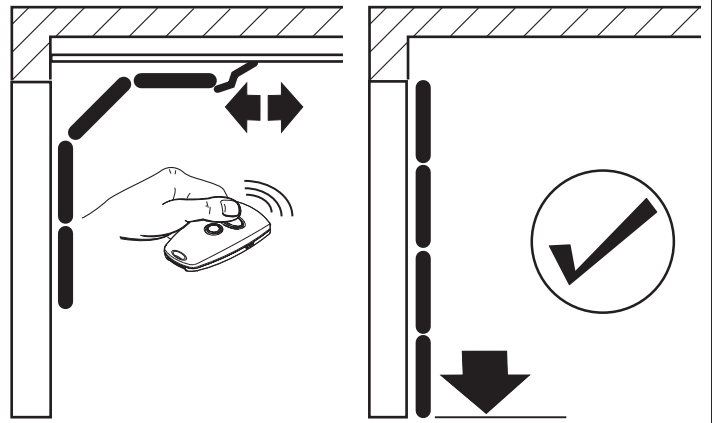

# 2. Special 301

2 / 1

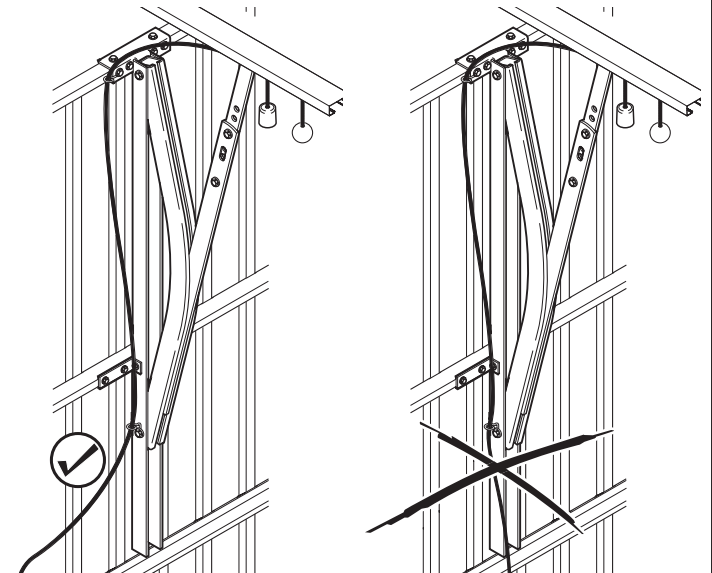

2 / 2

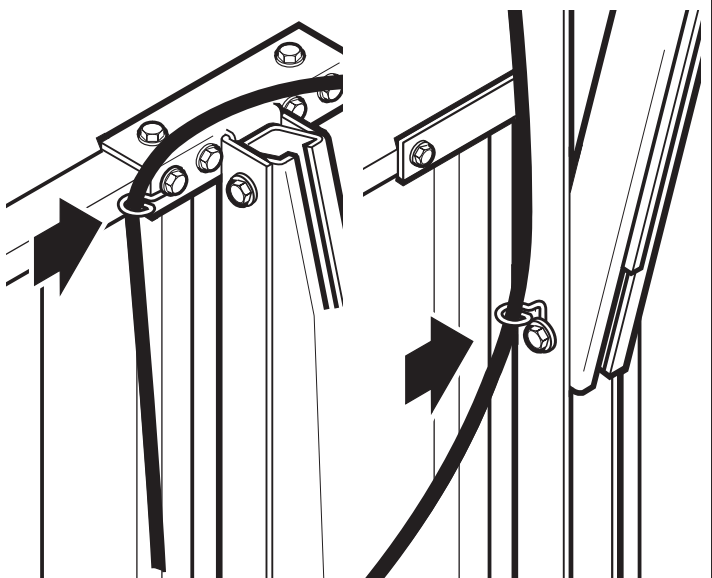

2 / 3

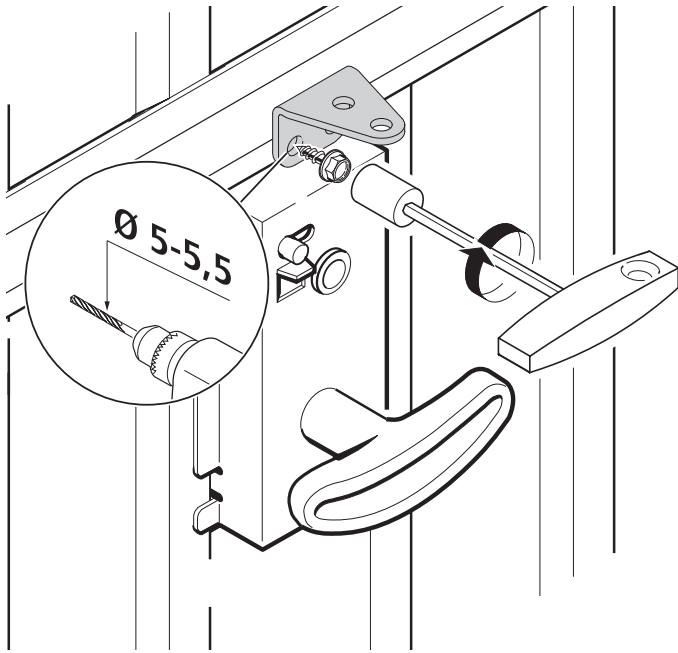

2 / 4

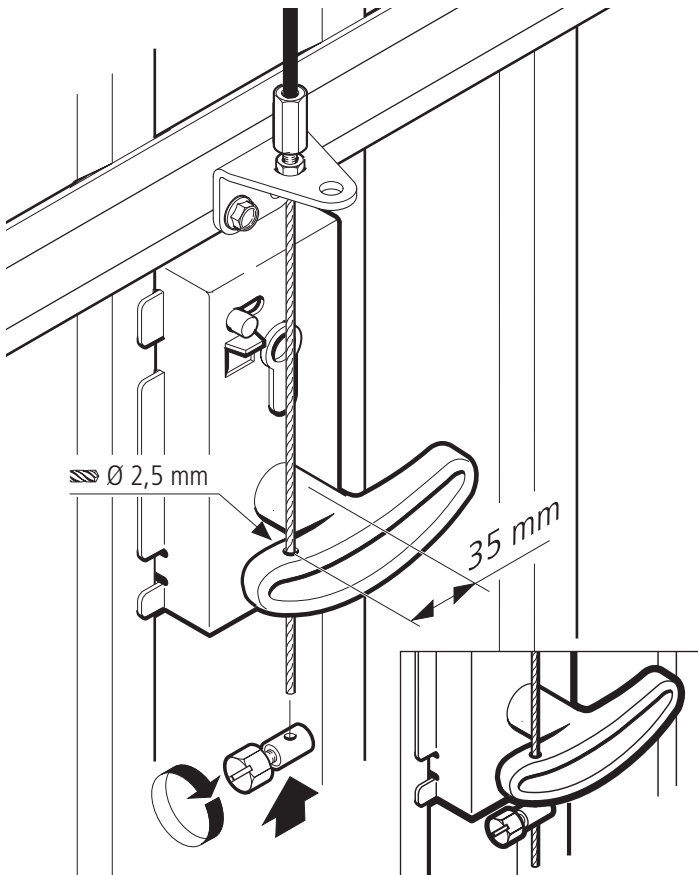

### 3. Special 302

3 / 1

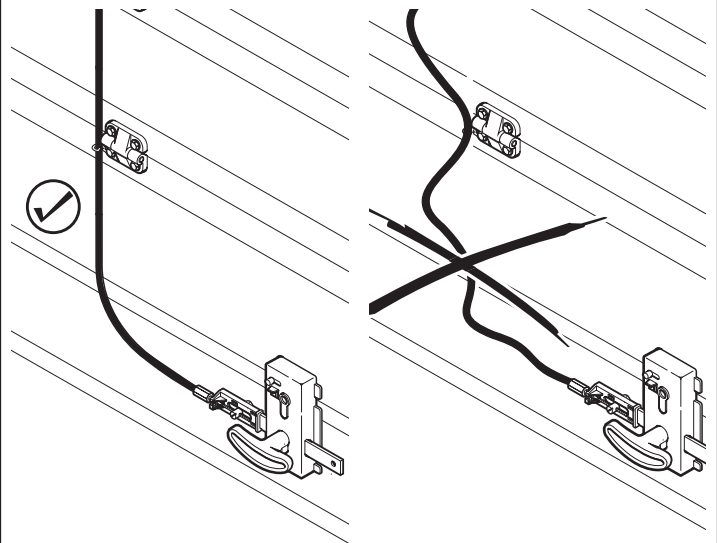

3 / 2

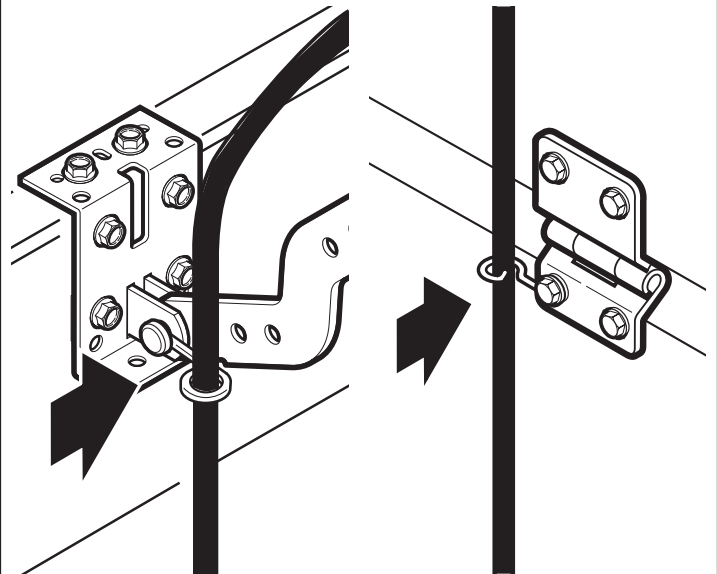

3 / 3

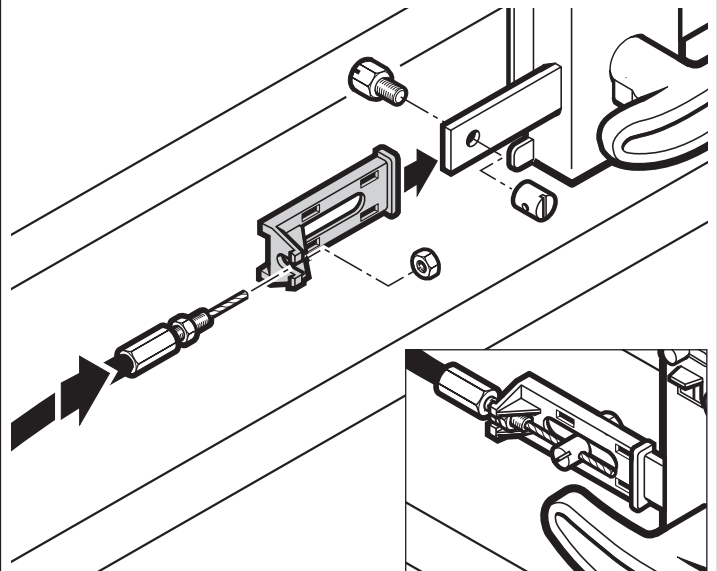

3 / 4

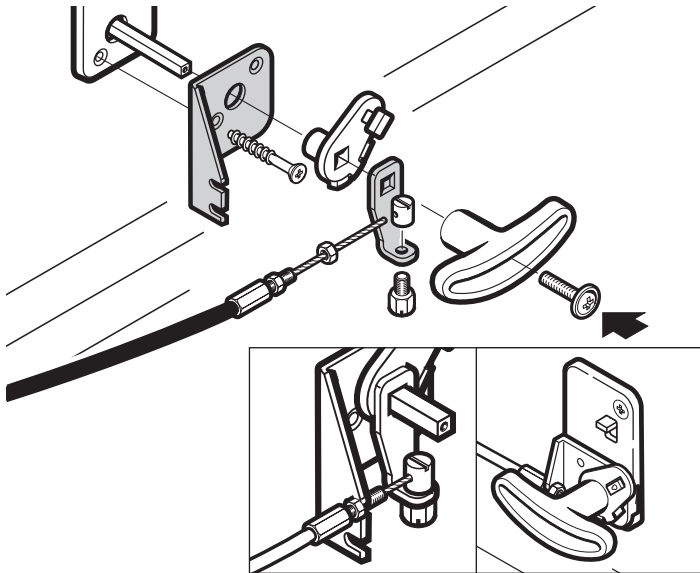

## 4. Special 303

4 / 1

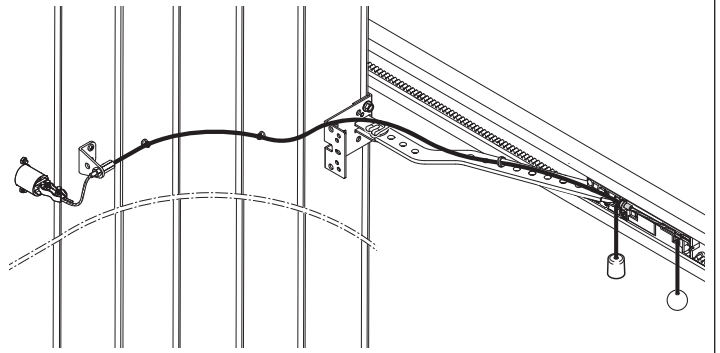

4 / 2

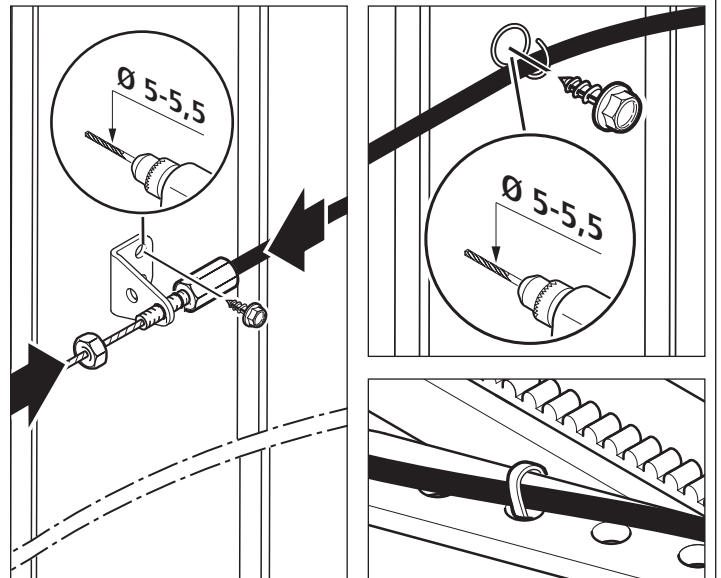

4 / 3

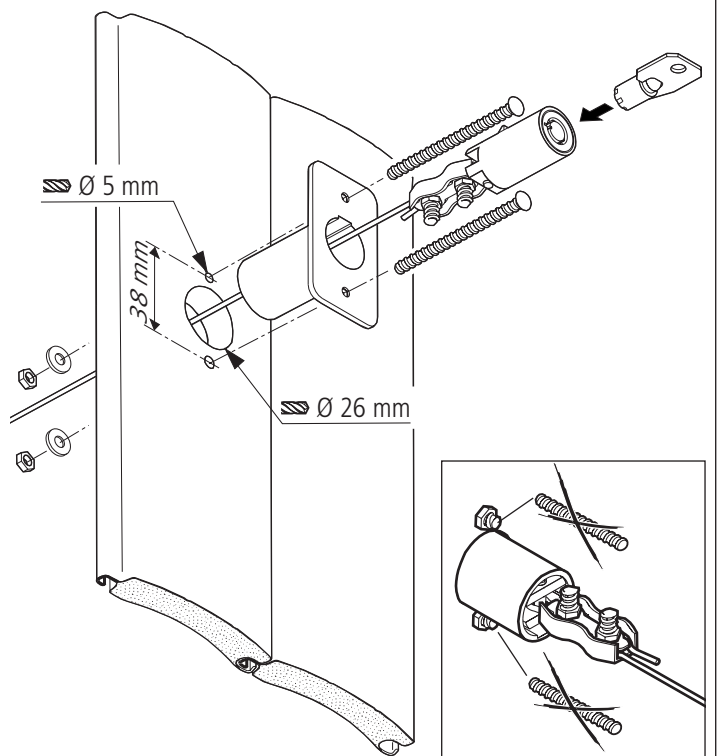

## 5. Special 304, 305

5 / 1

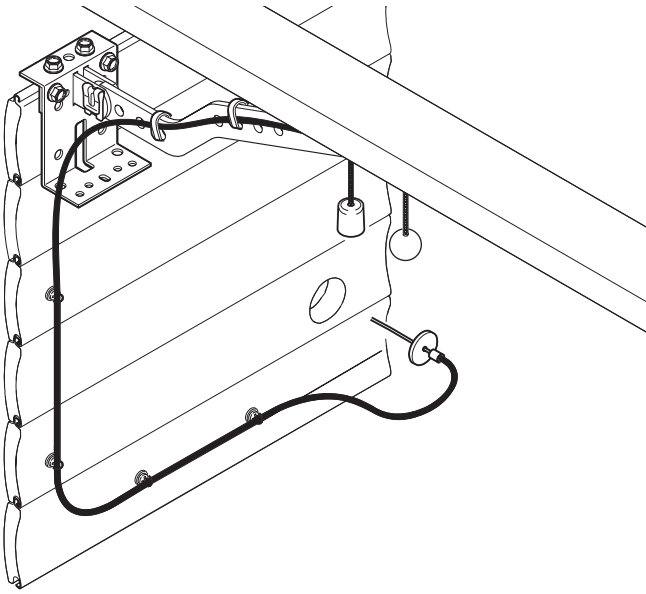

5 / 2

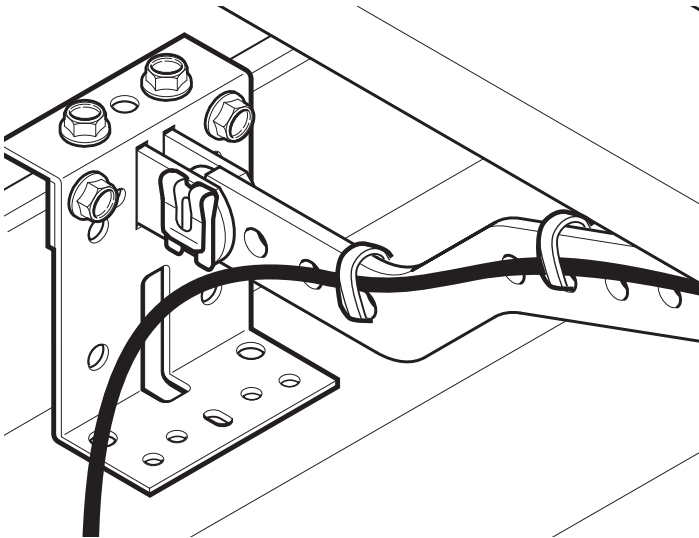

5 / 3

A

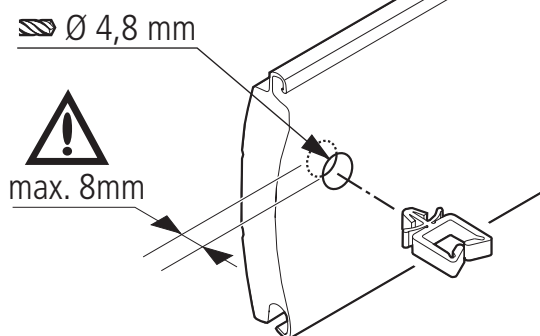

B

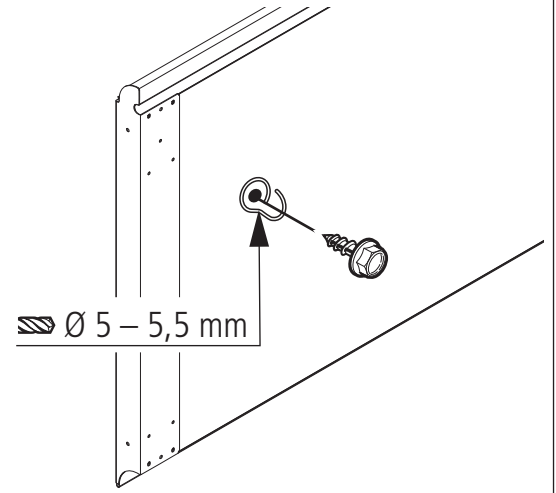

## 6. Special 304

6 / 1

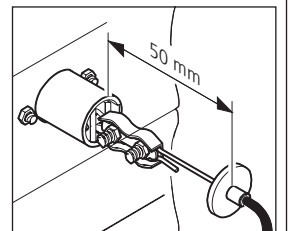
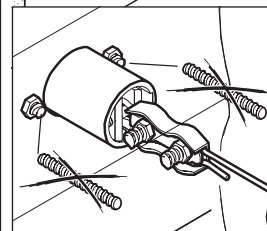
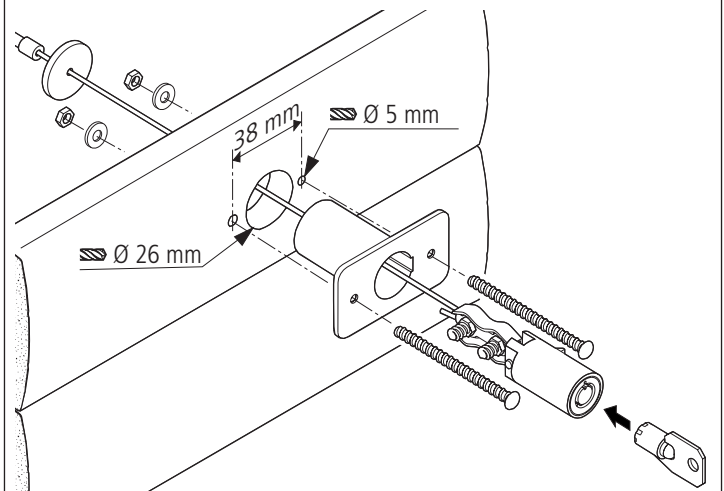

## 7. Special 305

7/1

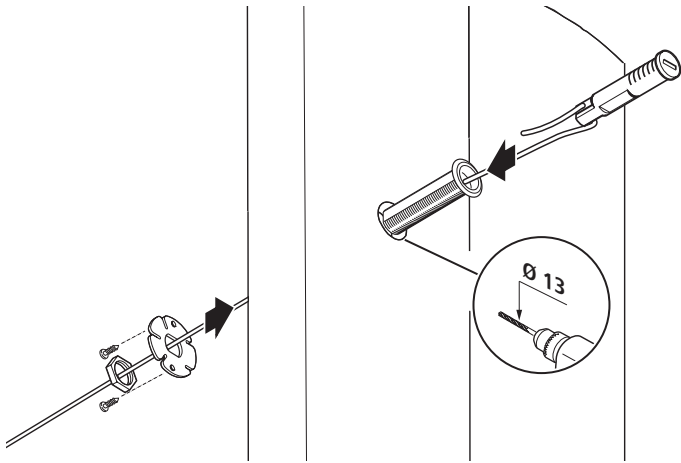

7/2

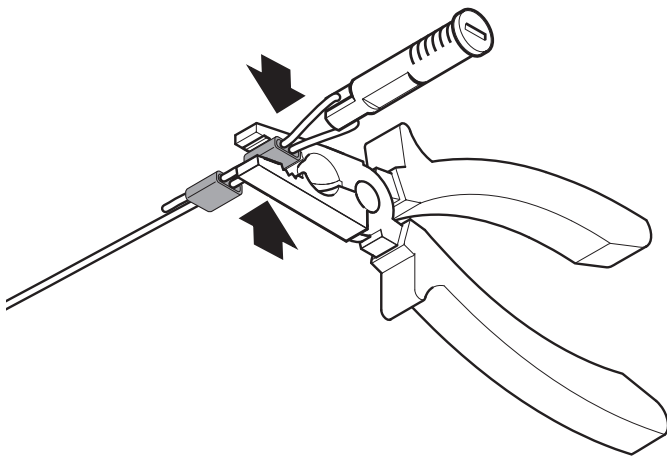

7/3

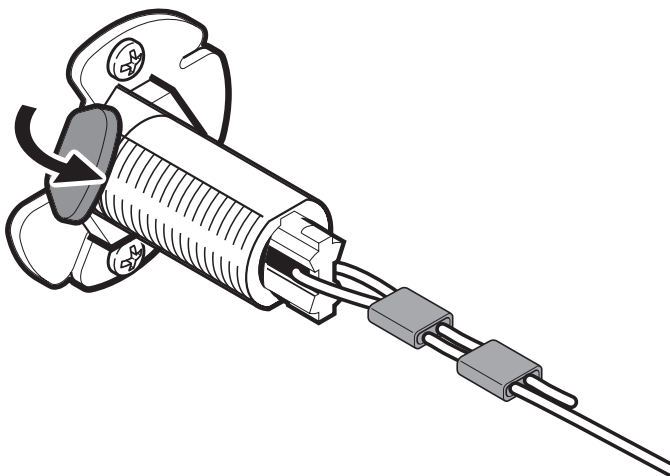

## 8. Special 306

8/1

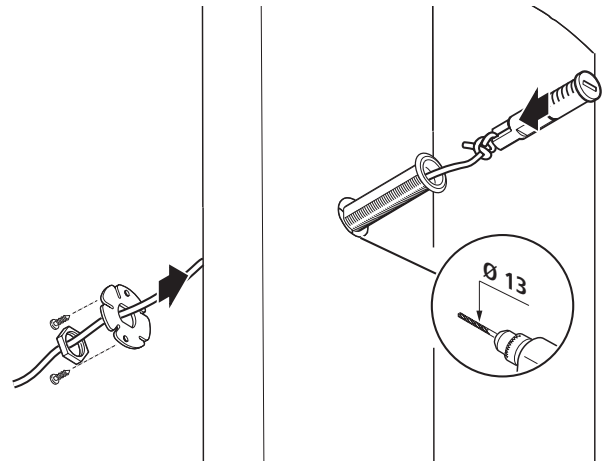

8/2

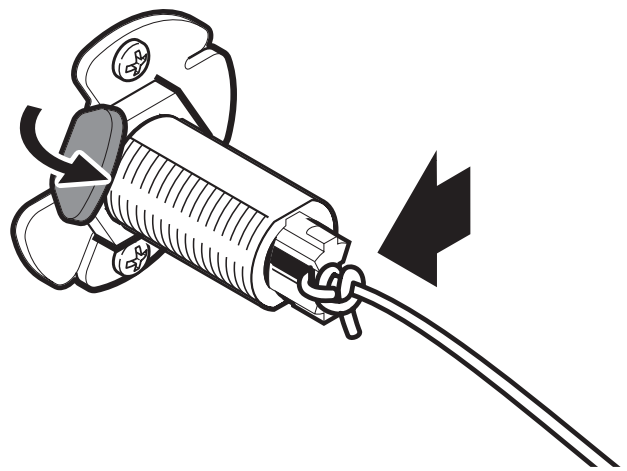

8/3

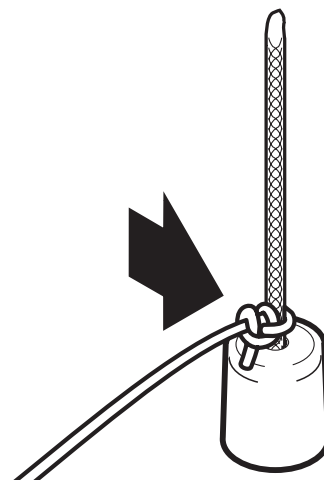

## 9. Special 304 + Comfort 515, 516

9 / 1

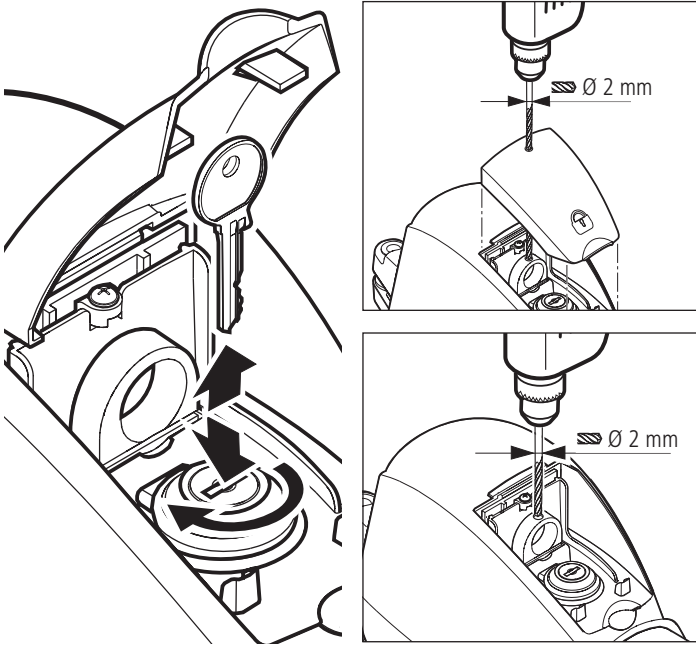

9 / 2

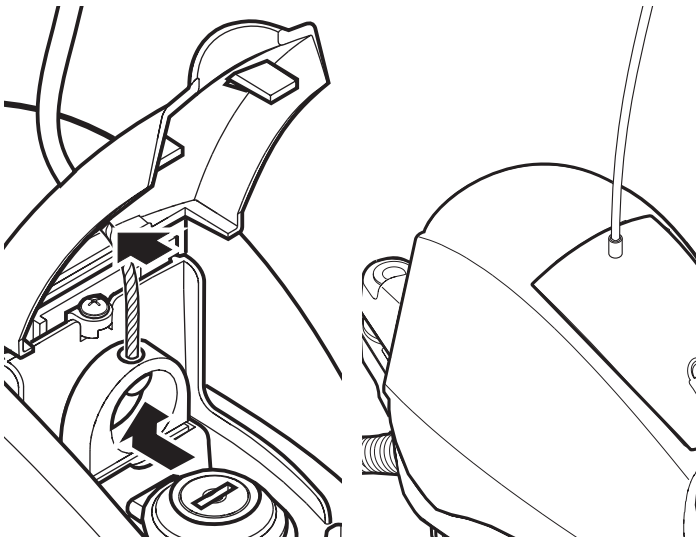

## 10. Special 311

10 / 1

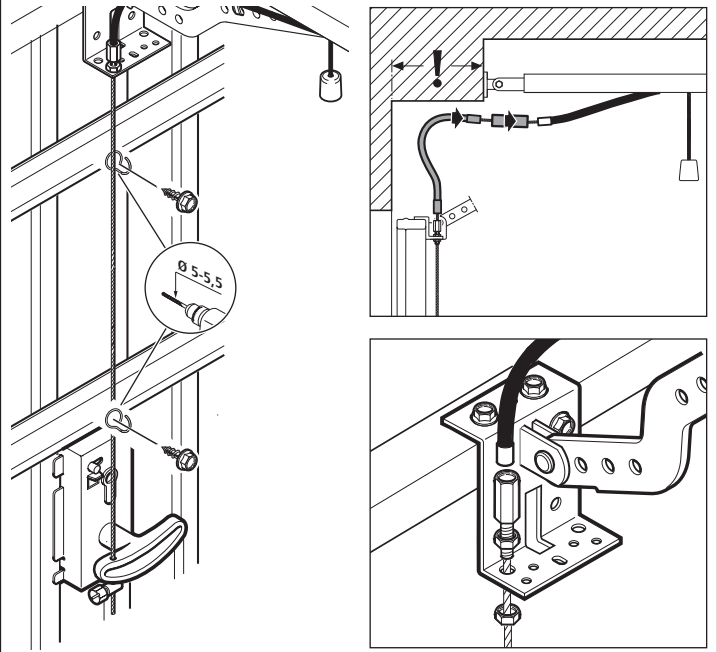

10 / 2

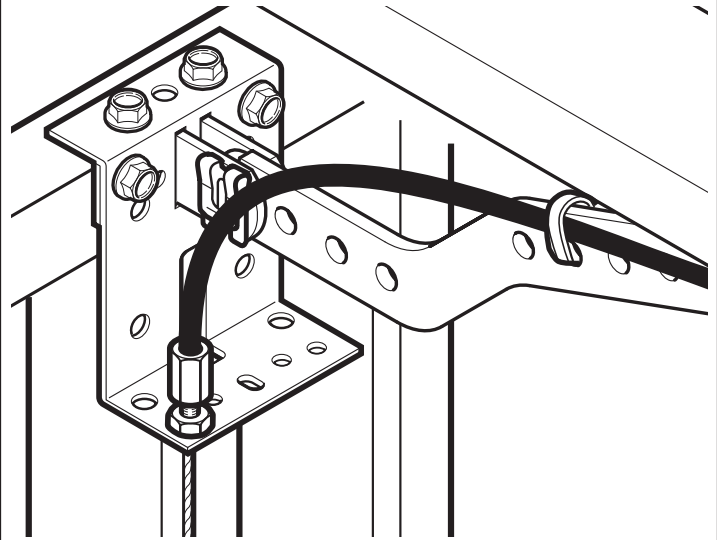

10 / 3

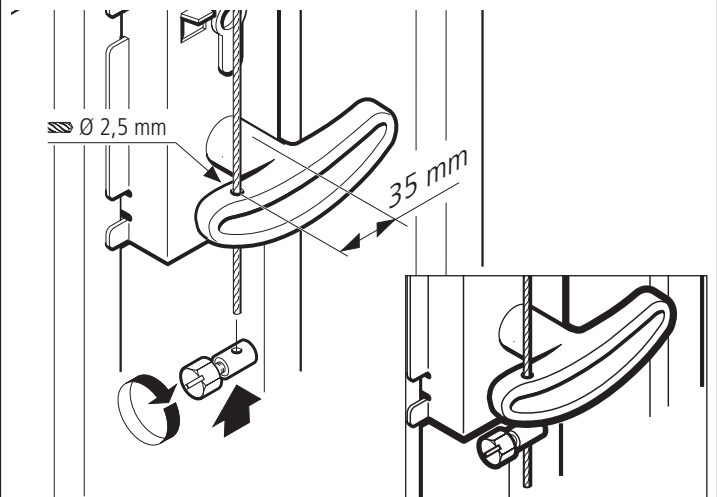

<b>D</b>
<b>Funktionskontrolle</b> Nach erfolgter Montage, muss die Notentriegelung geprüft werden. Die Prüfung muss alle 6 Monate wiederholt werden.
<b>GB</b>
<b>Functional check</b> After installation is carried out, the emergency unlocking device must be checked. This inspection needs to be repeated every 6 months.
<b>F</b>
<b>Contrôles de fonction</b> Après le montage, le déclenchement d'urgence doit être vérifié. Il faut répéter ce contrôle tous les 6 mois.
<b>NL</b>
<b>Functiecontrole</b> Na montage dient de noodontkoppeling te worden gecontroleerd. Deze controle moet om de 6 maanden worden herhaald.
<b>I</b>
<b>Controllo di funzionamento</b> Una volta conclusa l'installazione deve essere controllato lo sblocco di emergenza. Questo controllo va ripetuto una volta ogni sei mesi.
<b>E</b>
<b>Control del funcionamiento</b> Una vez efectuado el montaje, se tiene que comprobar el desbloqueo de emergencia. Hay que repetir la comprobación cada seis meses.
<b>P</b>
<b>Controlo de funcionamento</b> Depois de a montagem estar concluída, o destravamento de emergência tem de ser verificado. A verificação deve ser repetida a cada 6 meses.
<b>S</b>
<b>Funktionskontroll</b> Efter montering ska nödutlösningen kontrolleras. Denna kontroll ska upprepas var 6. månad.
<b>N</b>
<b>Funksjonskontroll</b> Når monteringen er avsluttet, må nødåpningen kontrolleres. Kontrollen må gjentas hver 6. måned.
<b>H</b>
<b>Működésellenőrzés</b> A sikeres összeszerelés után ellenőrizze a vészhelyzeti kireteszelést. Az ellenőrzést hathavonta el kell végeznie.
<b>SLO</b>
<b>Funkcijska kontrola</b> Po zaključeni montaži, preverite delovanje zasilnega odpahovanja. Takšno preverjanje morate opraviti vsakih 6 mesecev.
<b>CZ</b>
<b>Kontrola funkce</b> Po provedené montáži se musí zkontrolovat nouzové odblokování. Kontrola se musí každých 6 měsíců opakovat.

<b>PL</b>
Kontrola działania Po zakończeniu montażu należy sprawdzić funkcję ryglowania awaryjnego. Badanie należy powtarzać co 6 miesięcy.
<b>LT</b>
<b>Funkcinė kontrolė</b> Pabaigus montuoti reikia patikrinti avarinį atsklendimą. Bandyką reikia kartoti kas 6 mėnesius.
<b>RUS</b>
<b>Контроль правильности функционирования</b> После выполнения монта. Проверку следует повторять через каждые 6 месяцев.
<b>DK</b>
<b>Funktionskontrol</b> Efter montering, skal, nødopløsningen kontrolleres. Denne kontrol skal gentages hver 6. måneder.



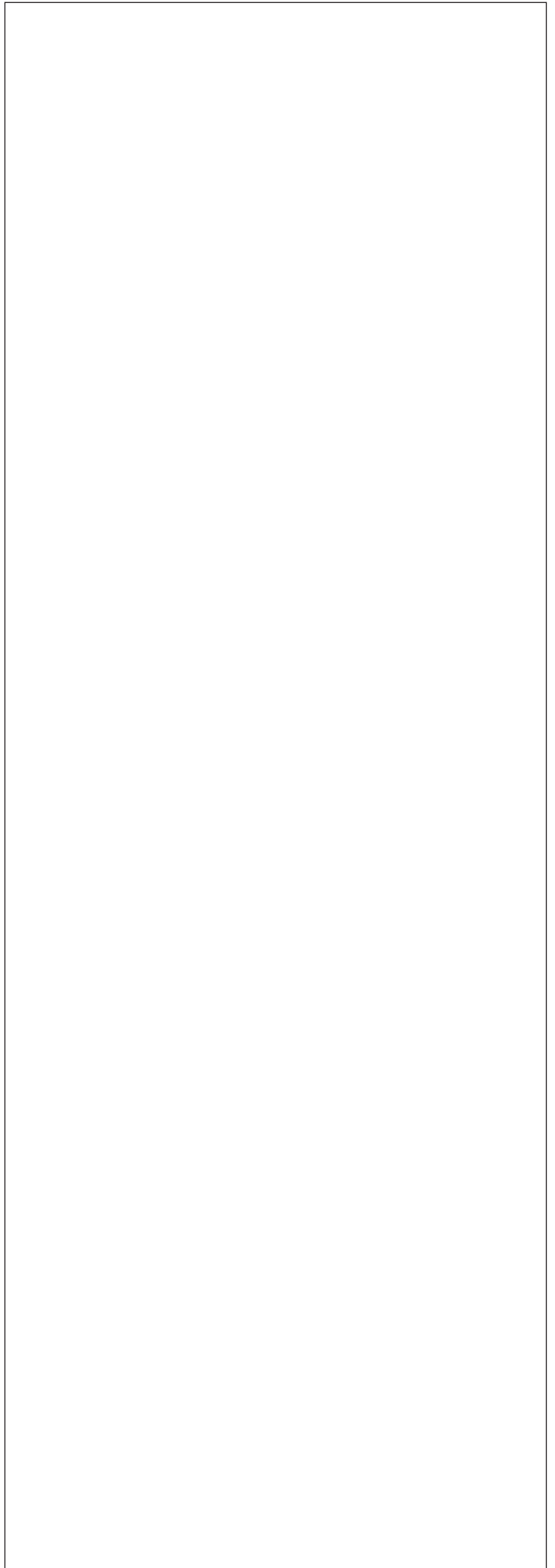
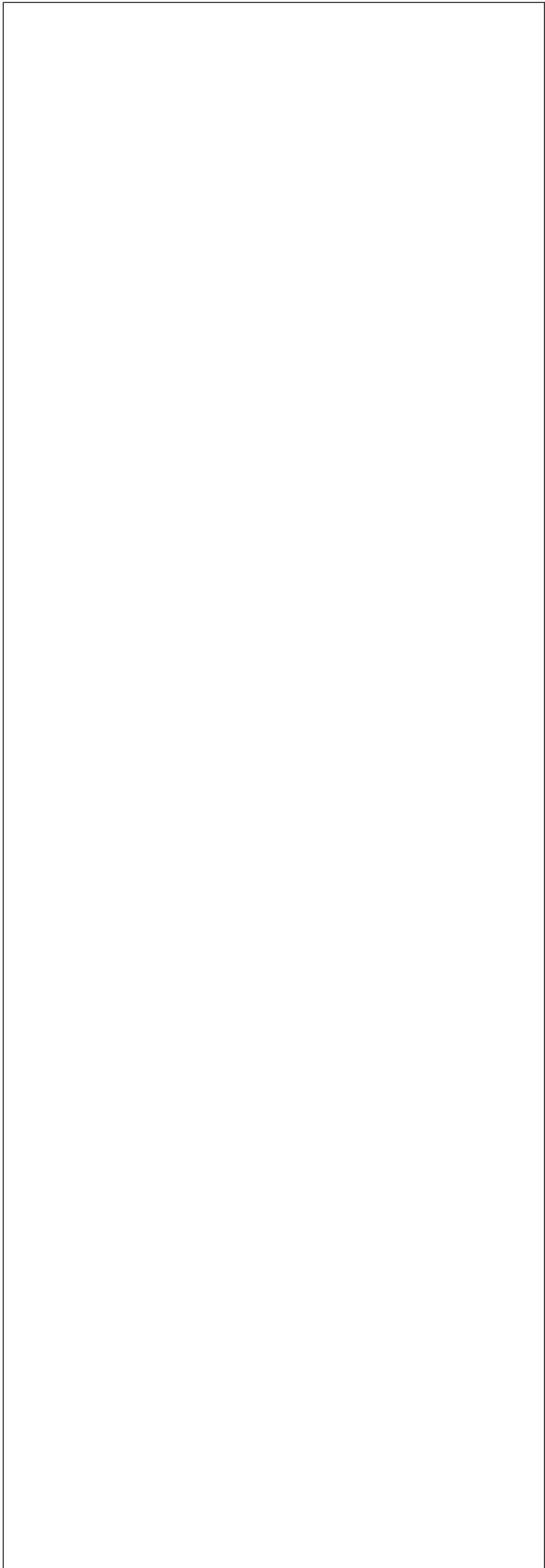

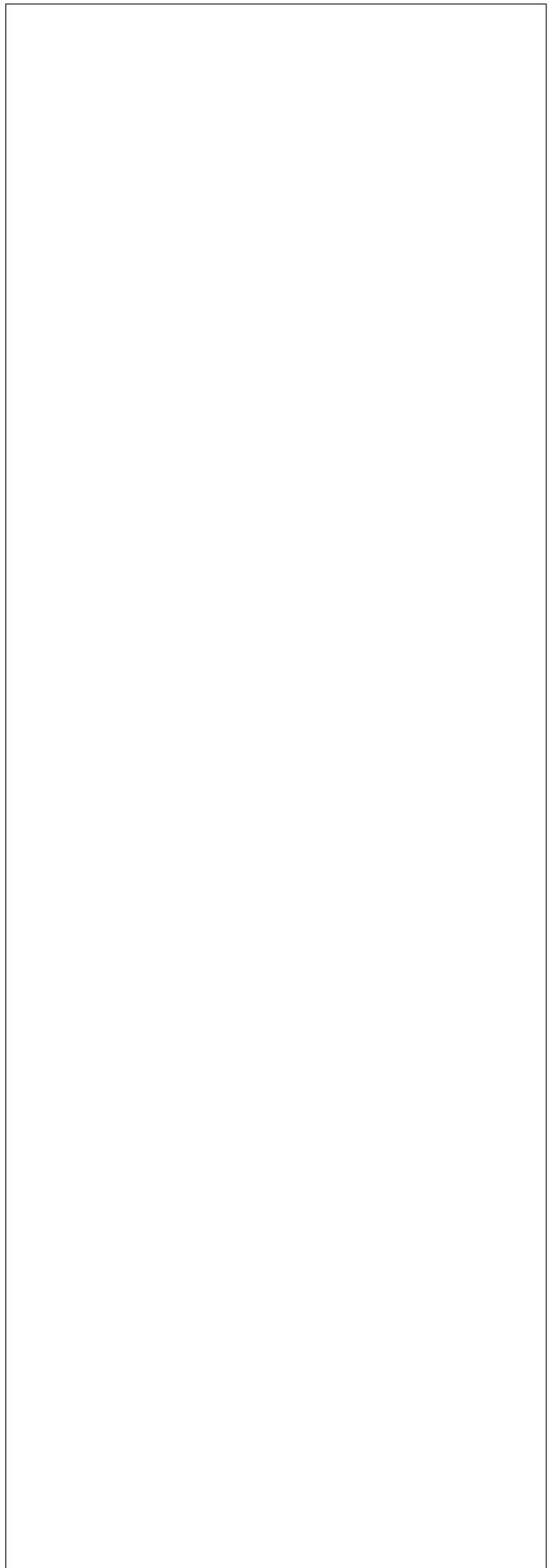
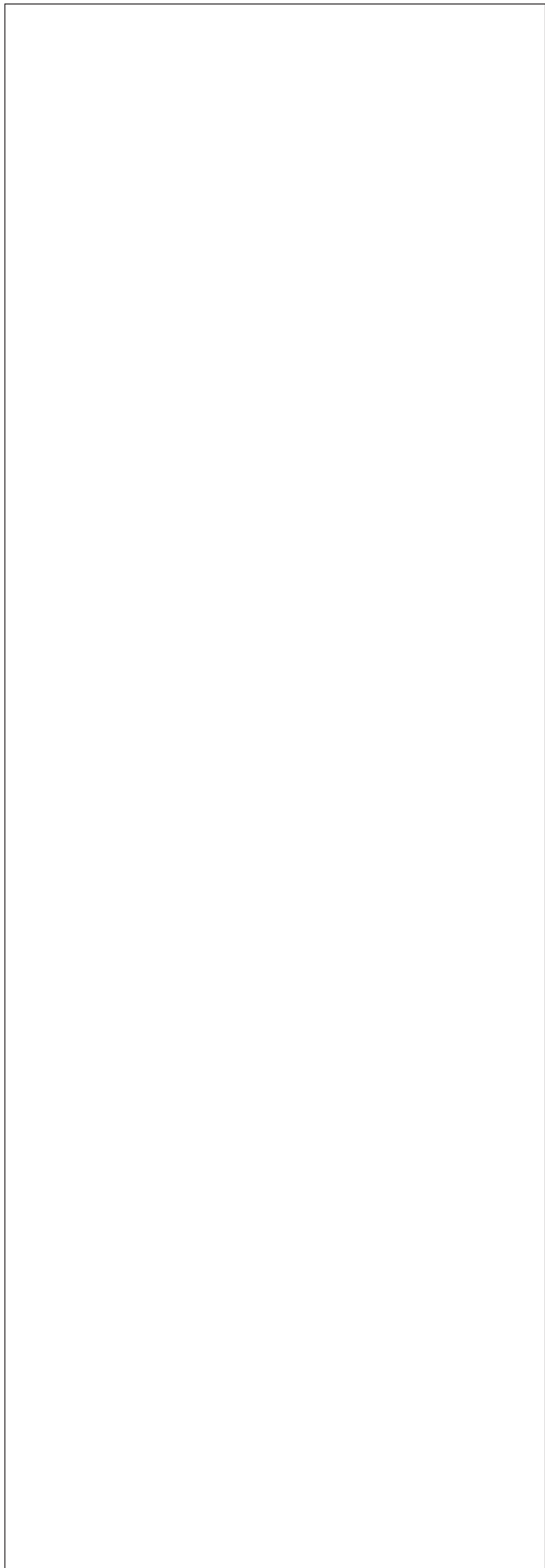

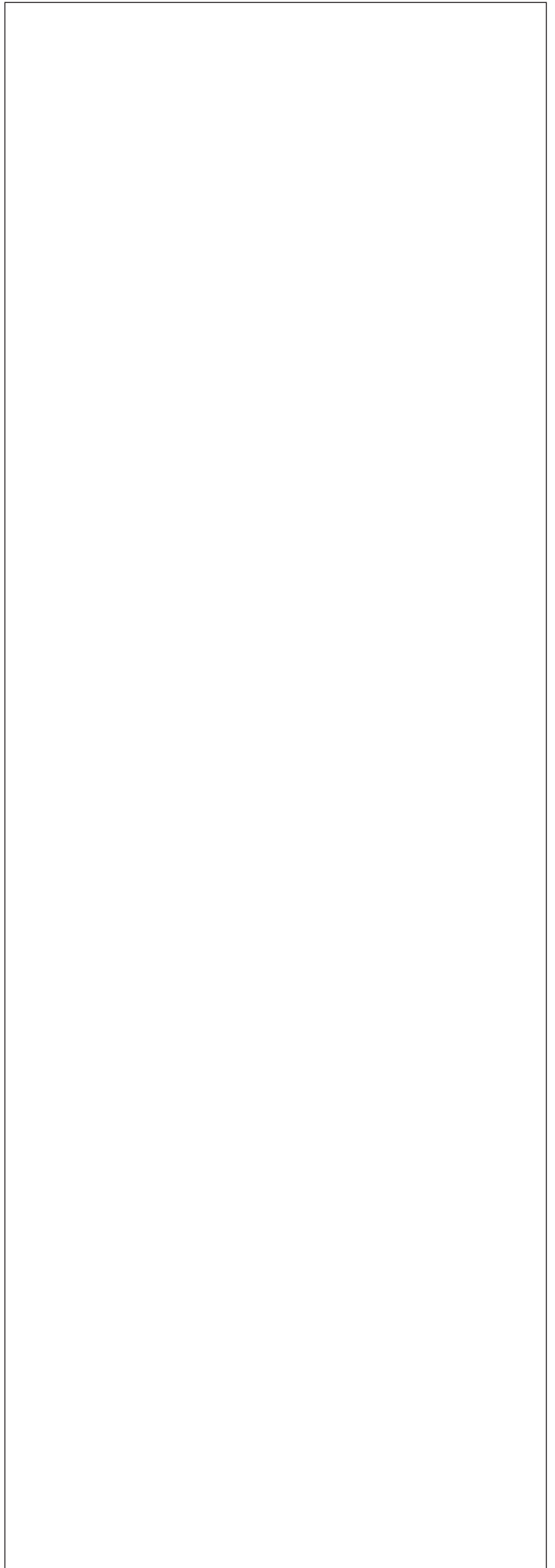
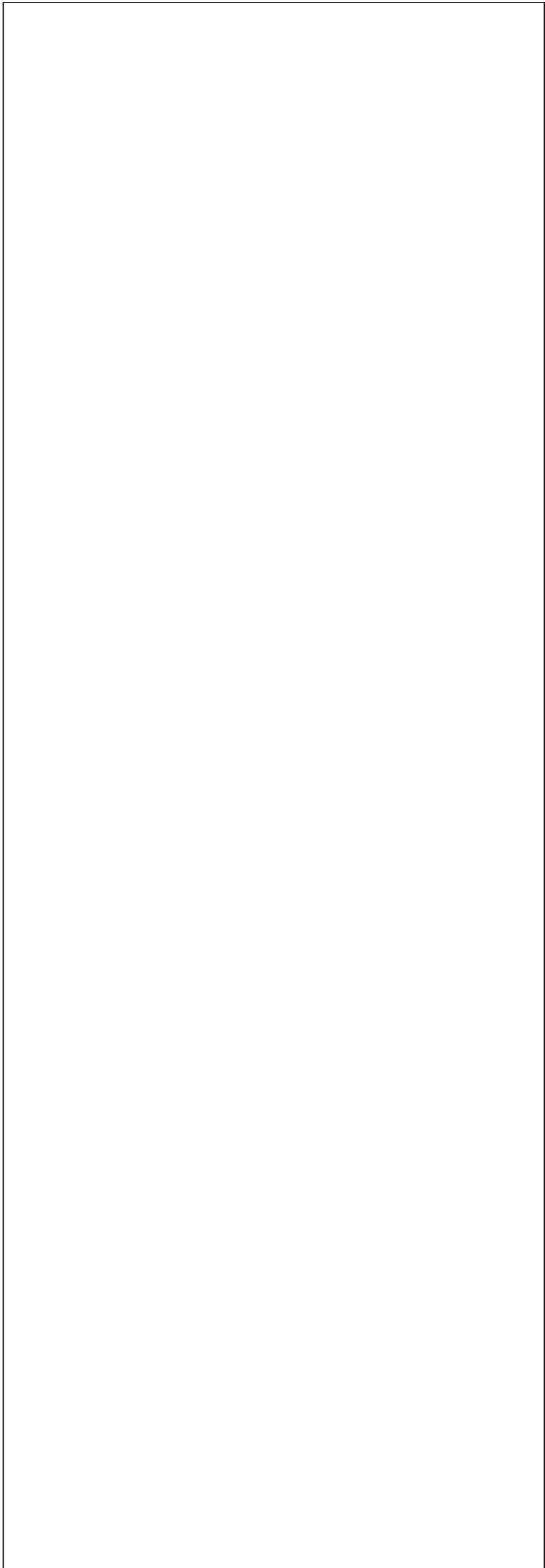

<b>DEUTSCH</b>	Originalanleitung, Urheberrechtlich geschützt. Nachdruck, auch auszugsweise, nur mit unserer Genehmigung. Änderungen, die dem technischen Fortschritt dienen, vorbehalten.	<b>MAGYAR</b>	Eredeti üzemeltetési útmutató. A jelen anyagot szerzői jog védi. Kinyomtatni, akárcsak kivonatossan is, csak engedélyünkel szabad. A műszaki haladás célját szolgáló módosítások jogát fenntartjuk.
<b>ENGLISH</b>	Original instructions, Copyright. No part of this manual may be reproduced without our prior consent. Subject to changes which are in the interest of technical improvements.	<b>SLOVENSKO</b>	Originalna navodila. Zaščiten z avtorskim pravom. Ponatis, tudi v izvečkih, je dovoljen le z našim dovoljenjem. Spremembe, ki služijo tehnični izboljšavi proizvoda, so pridržane.
<b>FRANÇAIS</b>	Notice originale, Copyright. Toute reproduction même partielle est interdite sans notre autorisation. Tous changements de constructions permis par l'évolution des techniques réservés.	<b>ČESKY</b>	Originální návod. Chráněno autorskými právy. Dotisk, i jen částí, možný pouze s naším svolením. Změny, které slouží technickému pokroku, vyhrazeny.
<b>NEDERLANDS</b>	Originele Gebruiksaanwijzing. Door de auteurswet beschermd. Niets uit deze uitgave mag worden verveelvoudigd en/of openbaar gemaakt door middel van druk, fotocopie, microfilm of op welke andere wijze dan ook zonder voorafgaande toestemming van de uitgever. Technische wijzigingen voorbehouden.	<b>POLSKI</b>	Instrukcja oryginalna. Chroniona prawem autorskim. Przy wykonywaniu przedruku, także fragmentów, konieczne jest uzyskanie naszej zgody. Zastrzegamy sobie prawo do wprowadzenia zmian wynikających z postępu technicznego.
<b>ITALIANO</b>	Istruzioni d'uso originali. Diritti d'autore riservati. Riproduzione, anche parziale, previa solo nostra autorizzazione. La Ditta si riserva la facoltà di apportare modifiche al prodotto in base al progresso tecnologico.	<b>LIETUVIŲ KALBA</b>	Originali instrukcija. Autorinės teisės saugomos. Kopijavimas, taip pat ir dalimis, tik su mūsų leidimu. Galimi technikos pažangos sąlygojami pakeitimai.
<b>ESPAÑOL</b>	Instrucciones originales. Copyright. Prohíbe la reproducción íntegra o parcial sin nuestra autorización. Reservado el derecho a modificaciones en el interés del perfeccionamiento técnico.	<b>РУССКИЙ</b>	Оригинальное руководство. Авторские права защищены. Перепечатка, даже выдержками, только с нашего разрешения. Мы оставляем за собой право на изменения, служащие техническому прогрессу.
<b>PORTUGUES</b>	Manual original de instruções. Reservados os direitos de autor. Reprodução, mesmo parcialmente, só com a nossa autorização. Sujeito a alterações que sirvam a evolução técnica.	<b>DANSK</b>	Originalvejledning. Ophavsretsligt beskyttet. Genoptryk, også i uddrag, kun med vores tilladelse. Ændringer, der tjener den tekniske udvikling, forbeholdes.
<b>SVENSKA</b>	Originalanvisning. Upphovsrättsskyddad. Eftertryck, även delvis, endast med vårt tillstånd. Med förbehåll för ändringar som tjänar den tekniska utvecklingen.		
<b>NORSK</b>	Original anvisning. Beskyttet opphavsrett. Ettertrykk - også i utdrag - bare med vår tillatelse. Endringer, som tjener den tekniske utviklingen, forbeholdes.		



\* 8 5 7 5 9 Y \*